

Next Generation Intelligent LCD Panels

DPP12232 Series Specifications

Version 1.2

Document Date: June 21, 2005

Copyright © by demmel products 2004 - 2005

Unless otherwise noted, all materials contained in this document are copyrighted by demmel products and may not be used except as provided in these terms and conditions or in the copyright notice (documents and software) or other proprietary notice provided with the relevant materials.

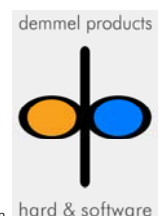

General Description

The iLCD modules are intelligent LCD panels which allow the user to carry out all graphic and font needs via an easy and comfortable way without having to deal with pixel addressing, low level functions or hardware details. Controlling the screen contents is done either via a serial port, I²C port or via USB.

Numbering System

Example:

DP	P	-	12864	G	3	7	7	1	3	-	B	F	H
1	2	3	4	5	6	7	8	9	10	11	12	13	14

Description:

No.	Description	Explanation
1	Brand	demmel products
2	Product	P = iLCD Panel
3	Separator	
4	Format	12232 = 132 x 64 dots 12864 = 128 x 64 dots
5	Display Type	B = Chip on board /w pin headers G = Chip on glass /w FCC connector Z = Chip on board /w FCC connector
6	iLCD Controller	1 = DPC1010 5 = DPC1050 3 = DPC1030
7	Control ports ¹⁾	0 = 5 Volt serial + I ² C 2 = USB port 1 = RS-232 port 4 = RS-422/RS-485 port
8	I/O Ports ¹⁾	0 = No I/O ports 2 = ATX power outputs 1 = General purpose I/O 4 = Relay outputs
9	Options ¹⁾	0 = No options 2 = Micro power reference 2.5 Volt 1 = Keyboard inputs 4 = Micro power reference 4.0 Volt
10	Power Supply ¹⁾	0 = Jumper only 2 = Built in regulator 1 = Floppy disk power supply
11	Separator ²⁾	
12	LCD manufacturer ²⁾	G = GiantPlus B = Bolymin
13	LCD Color ²⁾	G = STN/gray B = STN/blue Y = STN/yellow green F = FSTN
14	Backlight type/color ²⁾	L = LED array/yellow green D = LED edge/blue H = LED edge/white E = EL/white R = LED array/red B = EL/blue G = LED edge/yellow-green C = CCFL/white

Note:

1. The resulting number is calculated by adding the options' numbers.
2. These positions are omitted when the numbering system is used for iLCD controller boards.

Features

Display Specific Data

Item	DPP12232Zxxxxx-BYG
LCD Controller	SED1520
Display Format	Transflective and positive type graphic LCD 122 × 32 dot-matrix
Display Mode	Yellow Mode STN LCD
Backlight	Yellow/Green
Viewing Direction	6 O'clock

Electrical Specific Data

Item	All models (depending on installed options)
Connectivity	USB 1.1 / RS-232 / RS-232 5 Volt / RS-422 / RS-485 / I ² C
I/O Ports	4 general purpose ports (8 bit ADC 0..5 Volt or digital input or LED output), 2 LED outputs, keyboard with max. 32 keys, 2 relays outputs with 100 mA, ATX power switch in, ATX power switch out, PC reset switch in, PC reset switch out, built in 5 Volt regulator with up to 12 Volt input voltage

Mechanical Specification

Item	Specification	Unit
Resolution	122 x 32	dots
Module Dimension	96 x 35	mm
View Area	60.5 x 18.5	mm
Dot Size	0.4 x 0.45	mm
Dot Pitch	0.44 x 0.49	mm

Maximum Ratings

Item	Symbol	Minimum	Maximum	Unit
Supply Voltage	V _{CC}	-0.3	5.5	V
Supply Voltage Unregulated ¹⁾	V _{UNREG}	-50.0	12.5	V
Input Voltage	V _{IN}	-0.3	V _{CC} + 0.3	V
Operating Temperature	T _{OPR}	0	50	°C
Storage Temperature	T _{STR}	-10	60	°C
Humidity			90	%RH

Note:

1. Only available when the built in regulator option is installed. The maximum input voltage depends also on the maximum current drawn by the iLCD module (limited by the maximum power dissipation of the built in regulator which is 500 mW).

Electrical Characteristics

Item	Symbol	Condition	Min.	Typ.	Max.	Unit
Supply Voltage	V _{CC}	-	4.75	5.0	5.25	V
Supply Voltage Unregulated ¹⁾	V _{UNREG}	-	6.0	-	12.5	V
Input Voltage H Level ²⁾	V _{IH}	-	0.7 V _{CC}	-	V _{CC}	V
Input voltage L Level ²⁾	V _{IL}	-	0.0	-	0.8	V
RS-232 Input Voltage Operating Range					±30	V
RS-232 Input Threshold Low	V _{IRL}	V _{CC} = 5V	0.8	1.3		V
RS-232 Input Threshold High	V _{IRH}	V _{CC} = 5V		1.8	2.4	V
RS-232 Input Hysteresis	V _{IRH}	V _{CC} = 5V	0.2	0.5	1	V
Current Consumption	I _{DD}	No ports active, B/L off		45		mA
B/L LED Current Consumption	I _{LED}	V _{CC} = 5V		40		mA
LED B/L Brightness	-	V _{CC} = 5V	8	11		cd/m ²

Note:

1. Only available when the built in regulator option is installed. The maximum input voltage depends also on the maximum current drawn by the iLCD module (limited by the maximum power dissipation of the built in regulator which is 500 mW).
2. For digital inputs only.

Module Function Description

Block Diagram

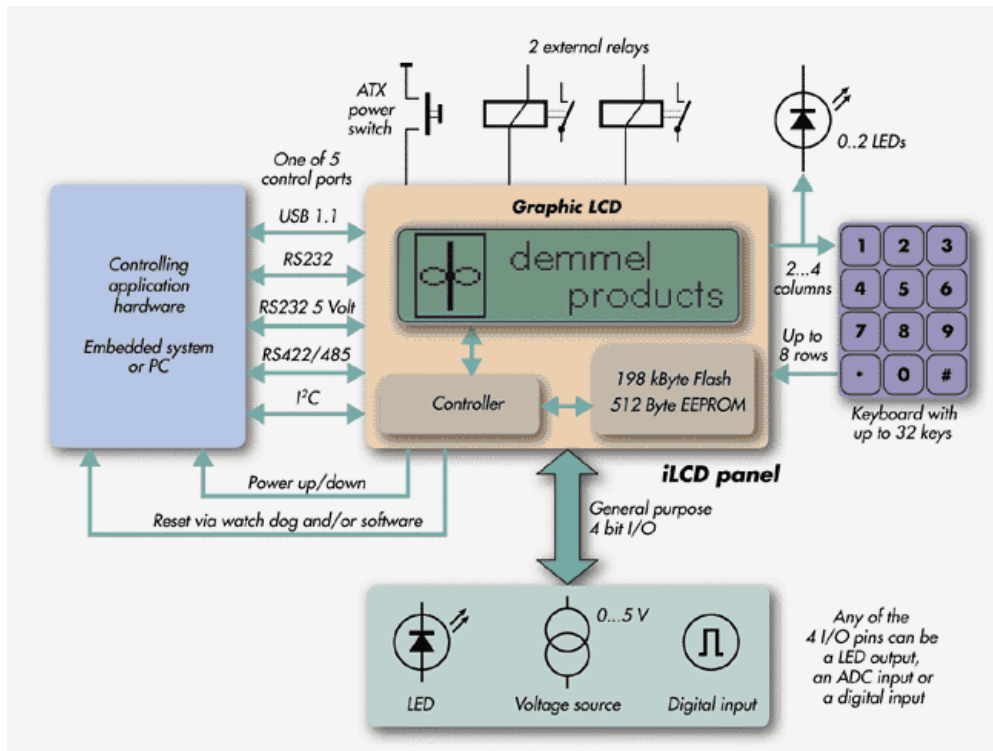

Connectors and Jumpers

This section describes and illustrates the connectors and jumpers of the iLCD DPP12232 series modules.

WARNING! Reversed power supply connections (Vcc and Gnd) made to the iLCD module or invalid power supply voltage greater than 5.5 Volt will cause module damage.

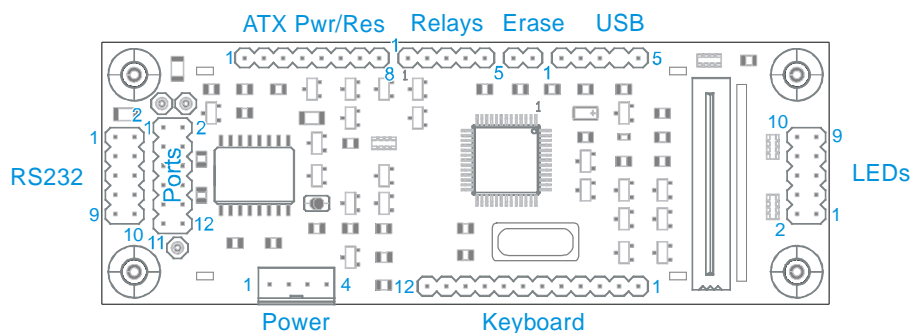

DPP12232 series connector and jumper locations

Power Supply Connector (Power)

This connector applies the 5 Volt power supply to the iLCD module if there is no USB port connected to the module. The connector used for this connection is the same as the power supply connector for a 3 ½" floppy disk drive, and has the same pinning.

Pin	Description
1	Not connected (floppy disk drive 12 Volt) V_{UNREG} Unregulated power supply 6 ... 12 Volt (save against reverse polarity)
2	Ground
3	Ground
4	V_{CC} (+5 Volt)

WARNING! The module should be supplied via this connector only if the USB port is not connected. Supplying the module via both connectors may damage the iLCD module.

Serial Port Connector (RS232)

This connector allows the driving application or PC to send and receive data from and to the iLCD module via standard RS232 signals. A cable can be made by simply using a straight flat cable connection between a 10 pin flat cable connector to a 9 pin female Sub-D (10th wire of the flat cable removed at the Sub-D side). The pinning will match the standard layout of a PC's serial port then.

Pin On Board	Pin On Sub-D	Direction	Description
1	1	-	Not connected
2	6	-	Not connected
3	2	Out	RX - data sent from the iLCD module to the controlling application / PC
4	7	In	RTS – not in use, but connected to the iLCD's RS232 driver
5	3	In	TX - data sent from the controlling application / PC to the iLCD module
6	8	Out	CTS – iLCD's output for hardware flow control ¹⁾
7	4	-	Not connected
8	9	-	Not connected
9	5	-	Signal ground
10	-	-	Not connected

Note:

1. See iLCD's command description about why you should connect this pin and when it is not necessary to use hardware flow control.

General Port Connector (Ports)

This connector enables you to connect the second RS232 port (**5 Volt signals only, no standard RS232 signal level of ± 9 Volt**), the I²C, and some other signals described below.

Pin	Direction	Description
1	-	Vcc (+5 Volt)
2	In/Out	I ² C Data ¹⁾
3	Out	RX2 - data sent from the iLCD module to the controlling application / PC
4	In/Out	I ² C Clock ¹⁾
5	In	TX2 - data sent from the controlling application / PC to the iLCD module
6	Out	I ² C Alert – signals unexpected data to be sent to the application (e.g. a keystroke)
7	Out	CTS - iLCD's output for hardware flow control – see iLCD's command description ²⁾
8	-	Used for production programming – DO NOT USE THIS PIN
9	In/Out	/RESET – Pulling this pin low resets the iLCD module ³⁾
10	-	Used for production programming – DO NOT USE THIS PIN
11	-	Ground
12		Used for production programming – DO NOT USE THIS PIN

Note:

1. This pin is pulled high via a 3k3 resistor on the iLCD board to match the I²C specification.
2. The 5 Volt CTS output connected to this pin is connected to the CTS port driver of primary RS232 port internally. This means that the iLCD's hardware flow control pin CTS is common for both RS232 ports.
3. The board's internal power up reset signal can be seen on this pin as well.

USB Connector (USB)

This connector enables you to connect iLCD's USB port to a USB port on a PC. The board is supplied via the USB connector as well.

WARNING! The module should be supplied via this connector only then if the power supply connector is not connected. Supplying the module via both connectors may damage the iLCD module.

Pin	Direction	Description
1	In/Out	USB+
2	-	Ground
3	In/Out	USB-
4	-	Pin does not exist. Used as a polarization key.
5	-	Vcc +5 Volt

General Purpose I/O Connector (LEDs)

Depending on the settings in the iLCD's setup software the four general purpose I/O ports can be a digital input, a LED output or an ADC input.

Pin	Direction	Description
1	-	Vcc +5 Volt
2	Out	LED 4 (Power LED)
3	Out	LED 5
4	In/Out	LED 0 output / ADC 0 input / General purpose input 0 ¹⁾
5	-	Not connected
6	In/Out	LED 1 output / ADC 1 input / General purpose input 1 ¹⁾
7	-	Not connected
8	In/Out	LED 2 output / ADC 2 input / General purpose input 2 ¹⁾
9	-	Ground
10	In/Out	LED 3 output / ADC 3 input / General purpose input 3 ¹⁾

Note:

1. The functionality of this pin is set via the iLCD's setup software.

Please note that LED 4 and LED 5 share the same controller outputs as column 2 and 3 of the keyboard. Although there is no visual effect when using LEDs, there are short glitches on the corresponding outputs when the keyboard is scanned, therefore it is not recommended to use this outputs for something other than LEDs. If column 2 / 3 of the keyboard is in use, LED 4 / 5 should not be turned on, as pressing a key can collide with iLCD's internal display processing routines.

Keyboard Connector (Keyboard)

The iLCD module supports up to 32 keys, which are connected in a matrix with 4 columns and 8 rows. The scan code / key code sent by the iLCD module can be set via the setup software for any of the 32 keys.

Pin	Direction	Description
1	In	Row 0
2	In	Row 1
3	In	Row 2
4	In	Row 3
5	In	Row 4
6	In	Row 5
7	In	Row 6
8	In	Row 7
9	Out	Column 0
10	Out	Column 1
11	Out	Column 2
12	Out	Column 3

Please note that LED 4 and LED 5 share the same controller outputs as column 2 and 3 of the keyboard. Although there is no visual effect when using LEDs, there are short glitches on the corresponding outputs when the keyboard is scanned, therefore it is not recommended to use this outputs for something other than LEDs. If column 2 / 3 of the keyboard is in use, LED 4 / 5 should not be turned on, as pressing a key can collide with iLCD's internal display processing routines.

PC ATX Power / Reset Connector (ATX Pwr/Res)

The iLCD module can power up/down a PC's ATX power supply and reset the mainboard of the PC: The connector layout is made in a way which allows further usage of the cables available in your PC.

Pin	Direction	Description
1	-	Ground / ATX power switch input (ground pin)
2	In	ATX power switch input ("hot" pin)
3	-	Not connected
4	Out	ATX power up/down (to the PC's main board)
5	In	Reset switch input (ground pin)
6	In	Reset switch input ("hot" pin)
7	Out	Mainboard reset (ground pin)
8	Out	Mainboard reset ("hot" pin)

To connect the PC's power and reset lines do as following:

1. Ensure your PC is switched off and the iLCD module is connected to the PC's power supply either via the floppy disk power supply cable or via the USB port.
Never connect both connectors at the same time!
2. Locate the 2-wire cable connecting the ATX power switch with the corresponding connector on the mainboard.
3. Unplug this cable on the mainboard and connect it to the iLCD Pin 1 and Pin 2.
4. Make an additional 2-wire cable with a 2-pin 2.54 mm on both sides and connect the one side of this cable to the iLCD pin 3 and 4 and to the mainboard (where you have previously unplugged the original cable – see step 3) on the other side.
5. Press the ATX power switch and check out if the PC starts. If this is not true, unplug the new cable (see step 4) on one side and plug it in again with changed polarity. Now the PC should start if you press the ATX power switch again.
6. Turn off the PC again.
7. Locate the 2-wire cable connecting the PC's reset button with the mainboard.
9. Unplug this cable from the mainboard and connect it with pin 5 and 6 of the iLCD.
9. Make an additional 2-wire cable with a 2-pin 2.54 mm on both sides and connect the one side of this cable to the iLCD pin 7 and 8 and to the mainboard (where you have previously unplugged the original cable – see step 7) on the other side.
10. Ensure that you have connected the serial port connection or the USB connection to your PC accordingly and turn on the PC. Start the iLCD Setup & Test program, go to "Preferences" and select the appropriate COM port if you use the serial port connection and then press the "Test" button to ensure your communication with the iLCD module works correctly. Go to "Terminal" and, erase any contents of the "Command" area and enter "\iP!=" (without the quotes – this is the iLCD command for resetting the PC) and press the "Send" button. This should reset your PC in the same way as if you would have pressed the reset button on your PC. If this is not true, unplug the cable from pin 7 and 8 and plug it in again in opposite direction and send the sequence again by pressing the "Send" button – the PC should be reset now.

Relays Connector ([Relays](#))

The two relays, which may be connected to the iLCD board, can be supplied using up to 24 Volts. The iLCD module contains a diode for any of the two relays outputs to protect the switching transistor against reverse voltage. To enable the diodes to protect the transistors, the relay supply voltages must be connected to the board too.

Pin	Direction	Description
1	-	Relay 1 positive supply voltage
2	Out	Relay 1 output (minus pin of relay)
3	-	Ground
4	Out	Relay 0 output (minus pin of relay)
5	-	Relay 0 positive supply voltage

Relay 0 can also be used to drive a speaker or buzzer and relay 1 can be used to generate a pulse-width modulated output voltage when the iLCD controller chip hardware release is ≥ 3.0 . Please have a look to the extra document "iLCD Commands" to learn more about how to control these output ports in this case.

Erase Jumper ([Erase](#))

When a jumper is connected to this connector, the iLCD module erases all user data from the Flash memory at boot time. A corresponding message is shown on the LCD. Please remove the jumper after startup to avoid consecutive erasing of Flash contents at the next startup.

Command Set

Please see the extra document "iLCD Commands" which describes the common command set available for all iLCD modules.

Revision History

Date	Rev. #	Revision Details
June 21, 2005	1.2	Added hint not to use LED 4/5 when keyboard column 2/3 is in use
November 22, 2004	1.1	Added PWM information for Relay Outputs
February 27, 2004	1.0	First Issue

If you find any errors in this document, please contact demmel products at support@demmel.com